

# ELECTRIC DRIVE 15" SHOCK ABSORBER SHEAVE

The shock absorber sheave is designed to fit onto the gearbox input shaft. Remove the belts and standard 15" sheave from the gearbox input shaft. **DO NOT REMOVE BELT GUARD.**

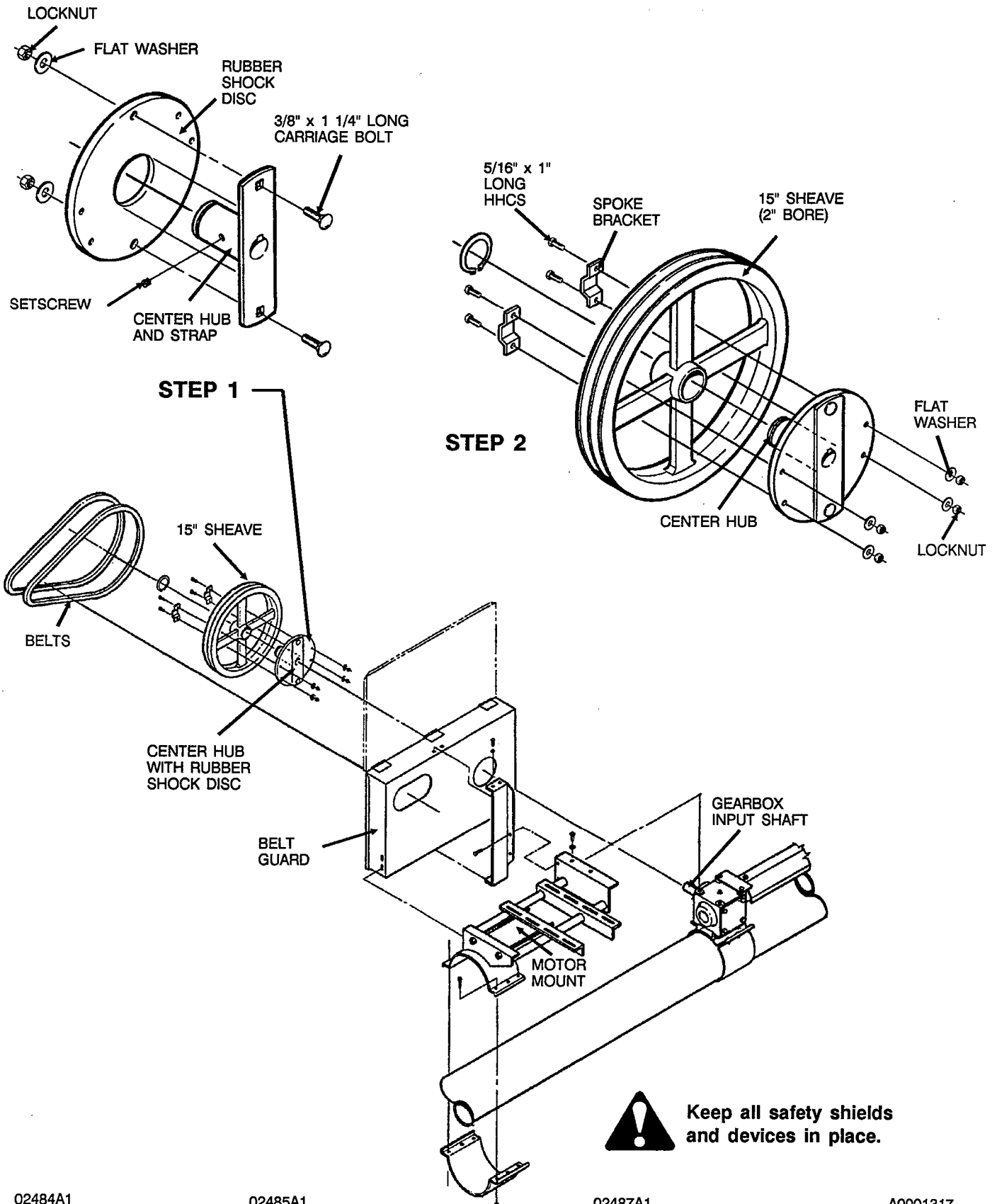

# ELECTRIC DRIVE 15" SHOCK ABSORBER SHEAVE

1. Slide the rubber shock disc over center hub and bolt to the strap with two 3/8" x 1 1/4" long carriage bolts, flat washer and locknuts. Slide the center hub all the way onto gearbox shaft. Tighten setscrew to secure the center hub to the gearbox shaft. NOTE: The setscrew must not extend past the outer surface of the center hub or the 15" sheave will not slide over the center hub.
2. Install the 15" sheave onto the center hub with the short side of the pulley hub against the rubber shock disc. Align motor pulley with 15" sheave by placing a straight edge across the outer faces of both the motor pulley and the 15" sheave. Secure the 15" sheave to the center hub by installing a snap ring. Use two spoke brackets and fasten the 15" sheave to the rubber shock disc with four 5/16" x 1" long HHCS, flat washers and locknuts.
3. Install belts and tighten.
4. Close and latch the belt guard door shut.



**DO NOT OPERATE THE UNIT AT ANY TIME WITH THE BELT GUARD DOOR OPEN.**

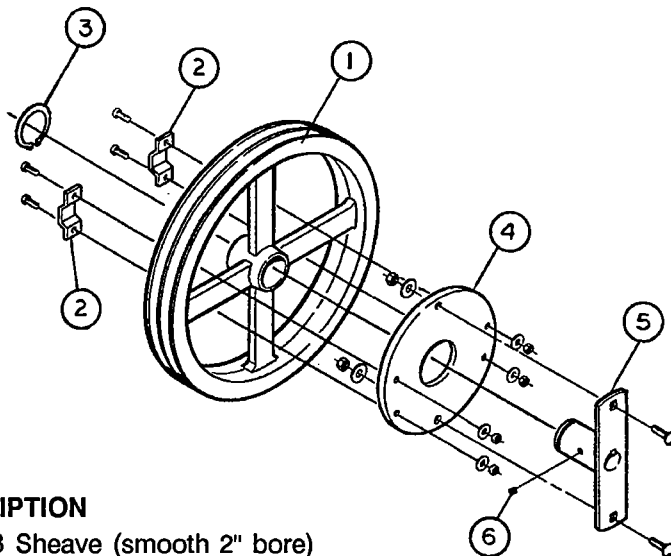

## PARTS LIST

REF. NO.	PART NO.	DESCRIPTION
1	1008186	15" - 2B Sheave (smooth 2" bore)
1	1008499	15" - 3B Sheave (smooth 2" bore)
2	1008181	Spoke Bracket
3	1008185	2" Snap Ring
4	1008182	Rubber Shock Disc (8" dia.)
5	1008188	1" Bore Center Hub with Strap
5	1008189	1 1/4" Bore Center Hub with Strap
6	33245	Setscrew 5/16" dia. x 5/16" long